

ACCESS INNOVATIONS GLOBAL

WORLD LEADERS IN
EARTH MOVING
ACCESS SAFETY SYSTEMS



www.accessinnovationsglobal.com



Graders 24H/M Mini Side Access

From the Global No.1 Access name who pioneered grader access in 1995.

The ONLY patented trademark Access Systems that Provide 100% Cab Access & 100% Operator view of the bald when operating.



24H - Benefits:

- Anti-slip stairs and platforms
- Unrestricted grader functions
- System is interlocked with the park brake circuit
- Park brake on – system platform and stairs lower for access
- Park brake off – system platform and stairs raised for grader operations

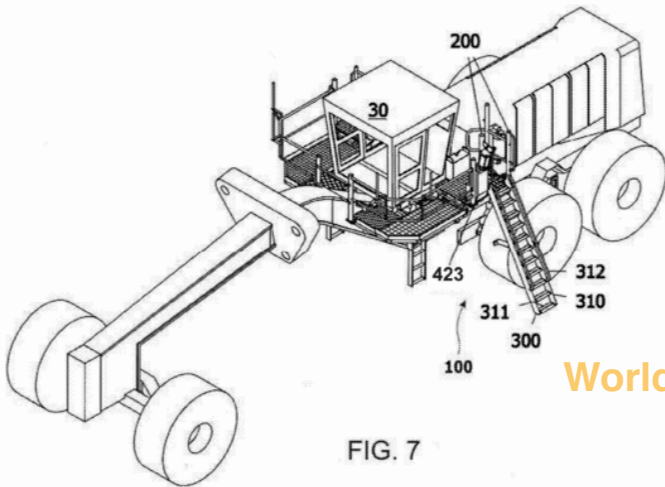

FIG. 7



World Leaders in Earth Moving Equipment Safety

Phone: +1-570-951-9861

Email: bobby@accessinnovationsglobal.com

www.accessinnovationsglobal.com



Graders 24H/M Mini Side Access

The Access Innovations Global Mini Side Access System always maintain a safe degree for ascent into the cab.
Provides SAFE walkways to clean windows and enter cab.
Provides 100% Cab Access
Provides 100% Operator View of the Blade when operating.



Emergency Exit

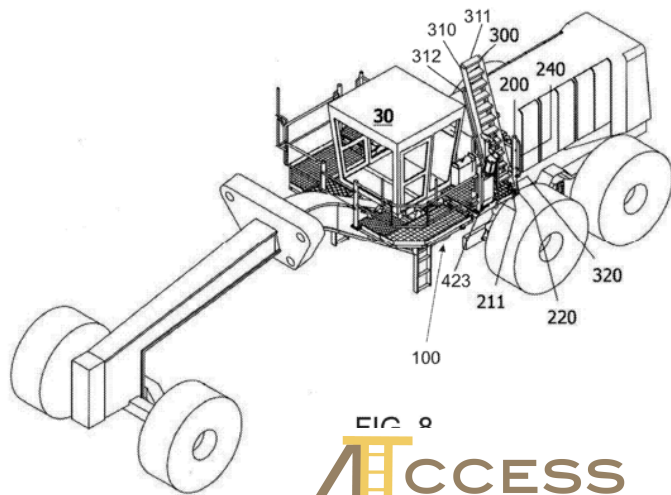

FIG. 2
**ACCESS
INNOVATIONS
GLOBAL**

World Leaders in Earth Moving Equipment Safety

Phone: +1-570-951-9861

Email: bobby@accessinnovationsglobal.com

www.accessinnovationsglobal.com



Graders - Side & Rear Access

Fits: Cat 16M/G/H, 24H/M, KOM825

The Access Innovations Global 24M & 16M access systems are the only patented trademark design that conforms with mining giants BHP & Rio Tinto's access and egress global safety protocols.



World Leaders in Earth Moving Equipment Safety

Phone: +1-570-951-9861

Email: bobby@accessinnovationsglobal.com

www.accessinnovationsglobal.com



Graders - Side & Rear Access

Fits: Cat 16M/G/H, 24H/M, KOM825



World Leaders in Earth Moving Equipment Safety

Phone: +1-570-951-9861

Email: bobby@accessinnovationsglobal.com

www.accessinnovationsglobal.com



Graders - Side & Rear Access

Fits: Cat 16M/G/H. 24H/M. KOM825



World Leaders in Earth Moving Equipment Safety

Phone: +1-570-951-9861

Email: bobby@accessinnovationsglobal.com

www.accessinnovationsglobal.com



What are people saying...

PTNNT Newmont Batu Hijau

Gents

While on leave I took the time to go and visit Access Innovations Workshop and have a look at some of the work they are doing for the Access/Egress of Caterpillar Graders.

While there I had the pleasure of looking at operating 16H Mini system that was fitted to a Cabin Jig, the system design utilizes the K.I.S.S principle in its function and manufacturing but delivers a high quality product to the end user without continued Maintenance/Repair requirements, these systems are built to last the life of the machine, and is evident in the quality of workmanship put into their product, the 16H Mini system is based on exactly the same design as the 24H/M full system without the rear walkways and access points.

- All Access/Egress functions are covered in the design to reduce all risk to Operations & Maintenance Personal
- All Access Innovation systems operates on air, the use of air for the system creates a smooth operation thus reducing any unnecessary shock loading to the folding sections of the platform.
- The stair mechanism works on a basis Rack & Pinion (brilliant in simplicity) design that reduces all the moving parts as seen on other Retractable Stair designs
- Once in the operating position and all platforms are retracted, the operator has unobstructed view of the ground and blade area the same as a grader without the system installed
- All mounting sections that bolt onto the Caterpillar Graders are approved by Cat
- Standardize parts across all Access Innovation systems
- Access Innovations only work on Access/Egress solutions, this is there only core business

Access Innovations are very passionate and proud about the work they do and in talking with their Founder/Designer, Mike Magnussen. It is understandable to see what drives him, as many years ago Mike was working at a Mine site as a Final Trim Grader Operation and during meal break noticed that a Team Member was missing from the lunch room at the go line. This team member was also Mike's Mentor for equipment operations.

He saw the team member's machine parked in the distance and decided to go and investigate. The team member had slipped from the cabin area while trying to clean the front windscreen of the grader and fell to the ground hitting his head on the grader blade.

Mike found him, the team member ended up having permanent loss of limb functions to one side of his body due to the accident. This is when Mike decided that instead of "**Just Accepting**" this is part of the "**Way we Operate**" the machines, he started looking for solutions to eliminate this risk

I have attached a couple of videos of the system in operation that was being run off a portable compressor along with the Rack & pinion Stair Mechanism (covers removed) to give you a better idea how the system works and a few general pictures.

Please forward onto the relevant groups

Regards

Brett Fairweather
Principle Technical Advisor- SCM & Operations Supports
PTNNT Newmont Batu Hijau
Phone-+628113949734
Email-brett.fairweather@nnt.co.id



World Leaders in Earth Moving Equipment Safety

Phone: +1-570-951-9861

Email: bobby@accessinnovationsglobal.com

www.accessinnovationsglobal.com



What are people saying...



Hi Mike

Since April 2013 when your D10T access system was installed on our dozer it has logged approximately 7000 hrs trouble free to date. The operators like the system, with visibility improvements over competitors' products. Whilst the maintainers were at first sceptical, due to the maintenance required on other systems, there has been absolutely no work required on this system since the day it has been installed.

Similar Dozer Access Systems on site have had on going repair costs and costly downtimes, as not made anywhere near the simplicity as Access Innovations Dozer Side Access System and most of all the rugged trouble free design.

This is proven on site and we are now installing a second Access Innovations Dozer Side Access System onto a D11R Dozer.

Regards,

Dave Waddell | Operations Manager / SSE | Downer EDI Mining Pty Ltd
T 07 4160 7230 | M 0407 444 724 | F 07 4160 7200
Meandu Mine, Nobby Smith Way, Nanango QLD 4615



World Leaders in Earth Moving Equipment Safety

Phone: +1-570-951-9861

Email: bobby@accessinnovationsglobal.com

www.accessinnovationsglobal.com



What are people saying...



Michael

Just a quick note to let you know how happy we are with the access stairway you fitted to our D11R a few weeks back.

The operators are very happy with it, visibility hasn't been reduced and access to the engine bay etc. hasn't been affected either.

To be honest we should have had it fitted years ago, it certainly has improved the safety aspect of accessing the dozer cab.

This Access Innovations Dozer Side Access System totally removes all the previous hazards of climbing over the blade push arms, walking up slippery coal tracks, then walking sideways hanging on to the engine bay, then hazardous steps to the cab deck.

This risky task was done numerous times each shift previously.

Now my men safely access the D11R via anti-slip staircase onto the cab deck with no exposure to slips or falls any more.

Thanks

Shaun Manthey
Coal Superintendent
Generation Operations
Tarong Power Station
Stanwell Corporation Ltd



World Leaders in Earth Moving Equipment Safety

Phone: +1-570-951-9861

Email: bobby@accessinnovationsglobal.com

www.accessinnovationsglobal.com