

ACCESS INNOVATIONS GLOBAL

WORLD LEADERS IN
EARTH MOVING
ACCESS SAFETY SYSTEMS



www.accessinnovationsglobal.com



Scraper - Front Access

Designed by Operators FOR Operators! Access Innovations Global™ provides the solution for safe access onto and around scrapers. Simple installation and minimal maintenance provides support to maximize production.

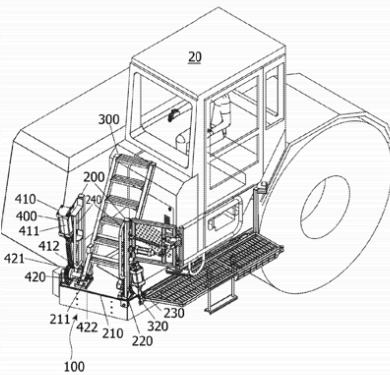
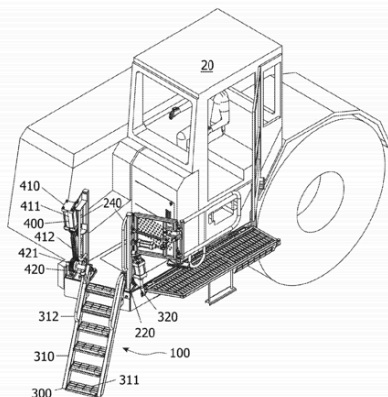
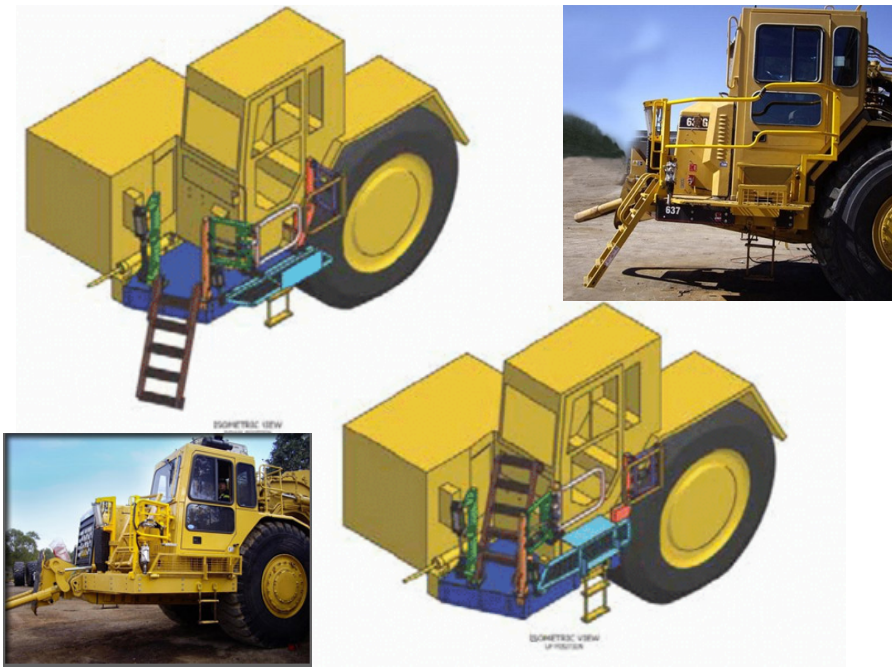

World Leaders in Earth Moving Equipment Safety

Phone: +1-570-951-9861

Email: bobby@accessinnovationsglobal.com

www.accessinnovationsglobal.com



Scraper - Rear Access

Safe Access is also for Mechanics. The Access Innovations Global Scraper Rear Access System provides safe, non-slip, 3-point contact for Operators and Mechanics to the rear of Scrapers. Fits around Fire Suppression systems. Simple installation and minimal maintenance provides support to maximize production.



**ACCESS
INNOVATIONS
GLOBAL**

World Leaders in Earth Moving Equipment Safety

Phone: +1-570-951-9861

Email: bobby@accessinnovationsglobal.com

www.accessinnovationsglobal.com

